

PRODUCED WATER TREATMENT SYSTEMS



Together creating pure
oil, gas and water.

ProSep offers a full line of proven solutions for handling produced water while keeping installations in compliance and online. The line includes primary, secondary, and tertiary treatment solutions for onshore, fixed-offshore, and floating-offshore facilities. All of the offerings have been proven over a broad spectrum of applications and years of strong performance.



Whether the goal is to re-inject for disposal or pressure maintenance, discharge to the surface or go overboard, ProSep can help producers to effectively treat produced water in a timely, smooth and cost-efficient manner.

PROSEP'S OFFERING

- Complete line of produced water treatment solutions
- Decades of combined industry experience and packaging expertise
- Proven and accepted conventional equipment designs
- Next-generation technologies
- Quality manufacturing and assembly
- Client-focused, customized, solution-oriented approach

PRIMARY SEPARATION

In a typical process flow, production enters a three-phase high-pressure separator, from which the output is water with



a 500-2000 mg/l oil-in-water concentration. Initial treatment of the produced water stream will be based on gravity separation principles to take the dispersed oil levels well below 500 mg/l.

TYPICAL PRODUCED WATER FLOW DIAGRAM

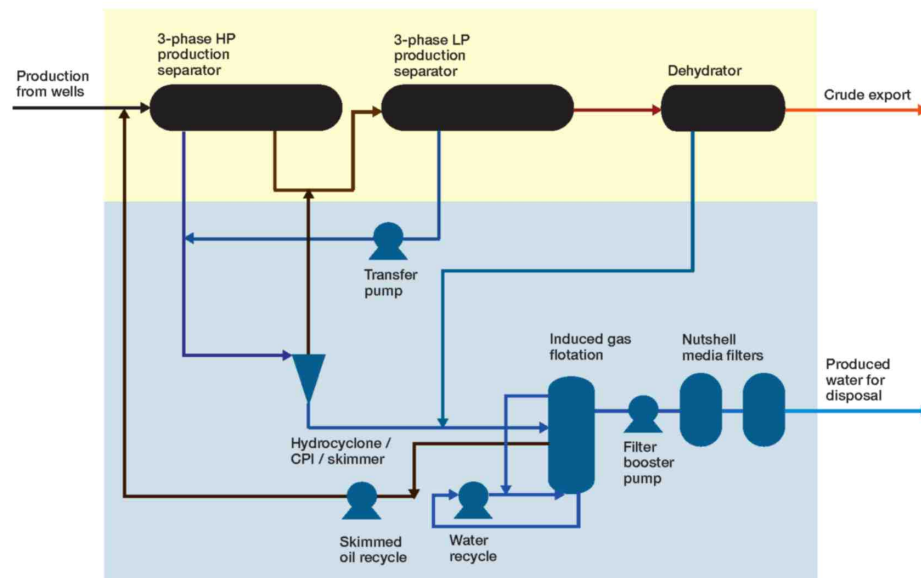

PROSPIN HYDROCYCLONE

The ProSpin Hydrocyclone is an excellent primary separation solution in most offshore applications where sufficient process pressure is available, since it has a small footprint and is highly efficient at separating free oil from water. ProSpin is unaffected by wave conditions and delivers typical removal efficiencies of 85-95% of all oil droplets >12-15 microns and typical effluent quality of 25-100 mg/l OiW.

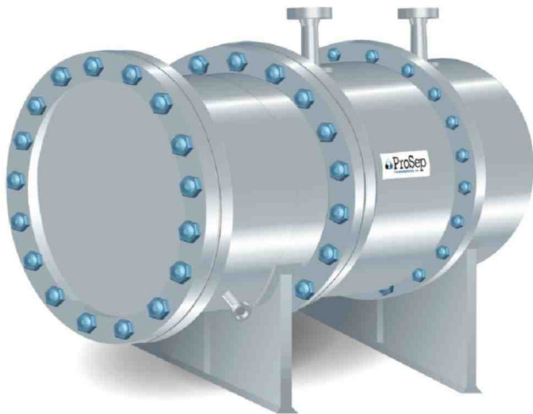

PROPLATE CPI OR PROSKIM VERTICAL SKIMMER

Handle surges and high percentage oil volumes and still deliver a 50-150 mg/l OiW concentration with ProSep's ProPlate Corrugated Plate Interceptors (CPIs) and ProSkim Vertical Skimmers. Where available pressure is less than 50 psig, or high inlet oil concentrations are expected, ProPlate

or ProSkim will often prove a better option for separation than hydrocyclones.

ProPlate CPIs are designed to provide the same removal efficiency as a traditional gravity separator in a much smaller vessel, making them ideal for fixed-platform as well as land-based installations. For floating applications with low pressure profiles, a CPI can be designed as a liquid-packed pressure vessel, mitigating the problems traditional atmospheric CPIs have with wave motions.

A ProSkim Vertical Skimmer can also serve as a motion-insensitive substitute for the CPI where process conditions warrant.

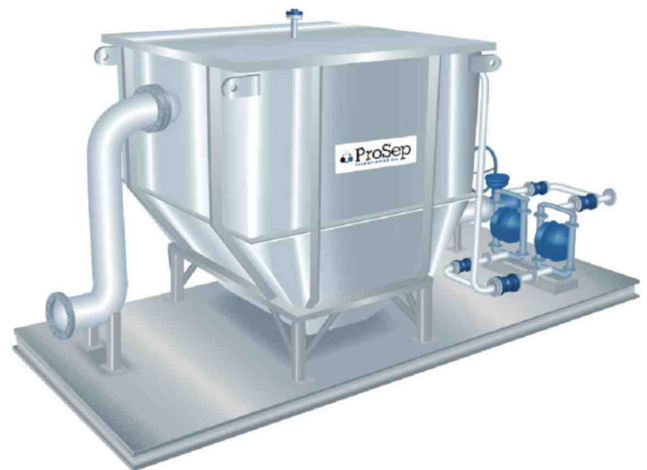

SECONDARY TREATMENT

After the first oil cut, the secondary stage of treatment conditions the produced water for overboard discharge, re-injection or further polishing through filtration. The secondary stage of treatment utilizes flotation principles to separate smaller and dispersed oil droplets. Discharge oil-in-water concentrations are typically below 25 ppmv.

PROFLOAT INDUCED GAS FLOTATION

ProSep's ProFloat Flotation Systems deliver highly efficient removal of oil and solids (10,000 to 100,000 BPWD with a separation efficiency of up to 98%) while completely containing the process. ProFloat is ideal for secondary treatment of produced and wastewaters in refineries, petrochemical plants and in the oilfield. The solution can integrate into existing systems as standalone vessels or be fully skid-mounted as a turnkey package.

An IGF is often selected over dissolved gas flotation because of issues of solubility of inert and fuel gas at the high temperatures characteristic of produced water processes. The ProFloat IGF is also a proven performer with thousands of installations worldwide in diverse applications. A ProFloat IGF vessel can be either a horizontal multiple-cell or a vertical single-cell.



The ProFloat IGF is available in horizontal multiple-cell when higher separation efficiencies and flow rates are required. ProSep's multiple-cell IGFs are ideal for many onshore and fixed offshore applications because of their ability to consistently achieve OiW concentrations in the range of 15mg/l.

SINGLE-CELL INDUCED GAS FLOTATION VESSEL

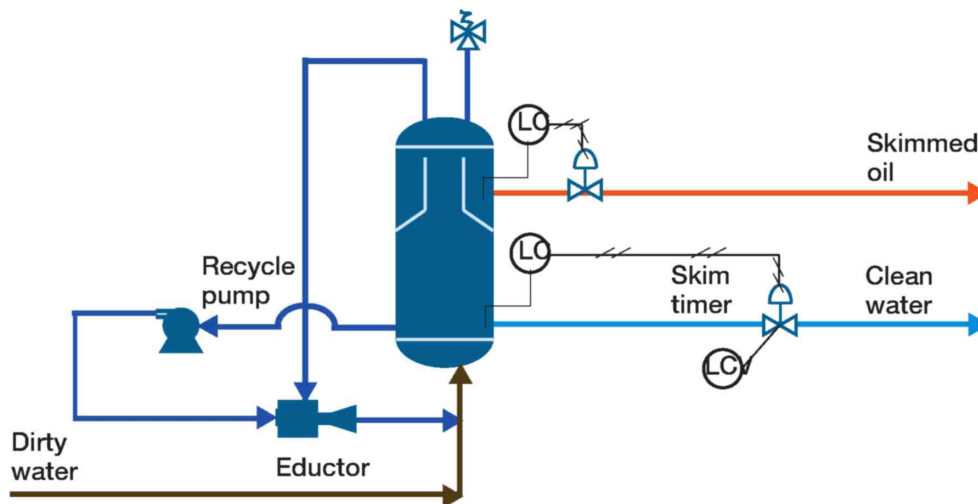

TERTIARY TREATMENT

Primary and secondary treatment will keep 90% of operators worldwide within either regulatory or self-imposed discharge limits. Depending on the reservoir matrix or discharge requirements, a maximum of 15-25 mg/l of oil and/or solids may not be sufficient. The third-stage of produced water treatment utilizes filtration to “polish” the remaining oil droplets and solid particles from the stream.

PROSHELL NUTSHELL MEDIA FILTER

ProSep provides high-performance tertiary treatment equipment employing nutshell media filtration.

ProSep provides high-performance tertiary treatment equipment employing nutshell media filtration. The use of nutshell media provides the benefit of reducing or eliminating the need for large quantities of backwash water, scouring, and surfactants. The unique qualities of the pecan / walnut shell media blend make for an effective, hydrophilic bed, which is extremely hard and durable. Thus the ProShell Deep Bed Nutshell Filter media lasts longer than traditional media and remains highly effective throughout the filter life-cycle, typically requiring 5-10% makeup volume per year.

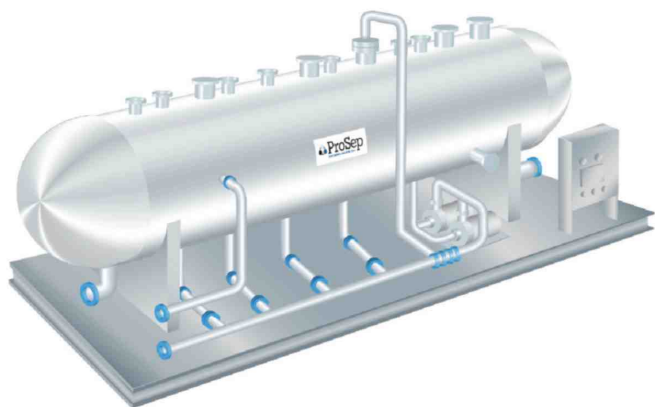

Under normal conditions represented by an inlet oil concentration of less than 50 mg/l and a comparable solids inlet concentration, nutshell filters will remove 95% of oil and solids larger than 5 microns. With the addition of chemicals, efficiencies can exceed 98% removal of particles greater than 3 microns.

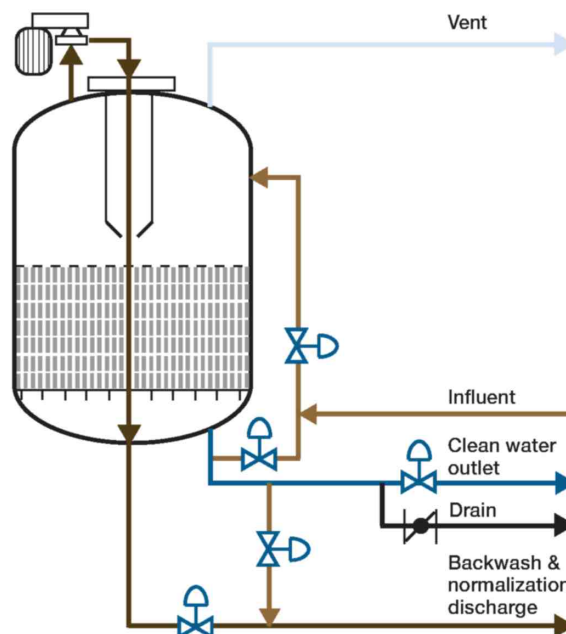
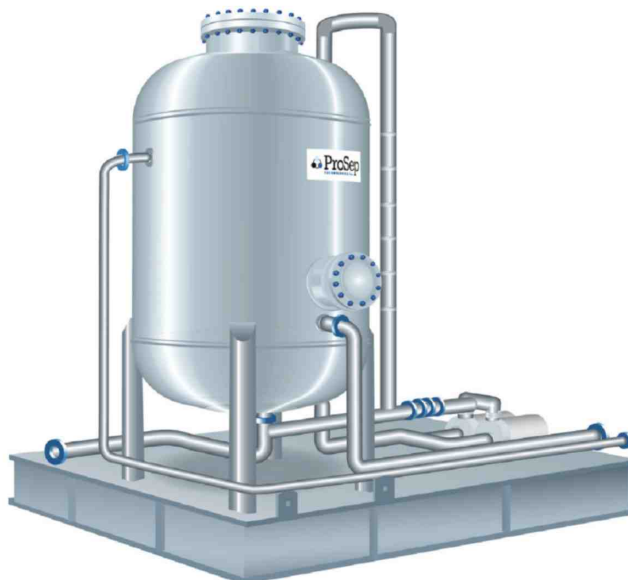

NEAR-ZERO DISCHARGE OFFERINGS

CTOUR PROCESS

In response to increasing produced water volume combined with stricter discharge legislation, ProSep offers the CTour process. The process is one of the only technologies in the world that can cost-effectively remove both dispersed and dissolved hydrocarbons from large volumes of produced water.

It does this through injecting a condensate of light hydrocarbons into the produced water stream to extract the harmful components. In addition to environmental advantages, the CTour process provides improved separation efficiency for debottlenecking produced water treatment problems.

ProSep offers the following for CTour:

- Prediction of performance
- Process definition for implementation
- Configuration and specification of equipment for full-scale installation
- Project support
- Commissioning, start-up assistance, and project support
- Field testing

TYPICAL CTOUR PROCESS

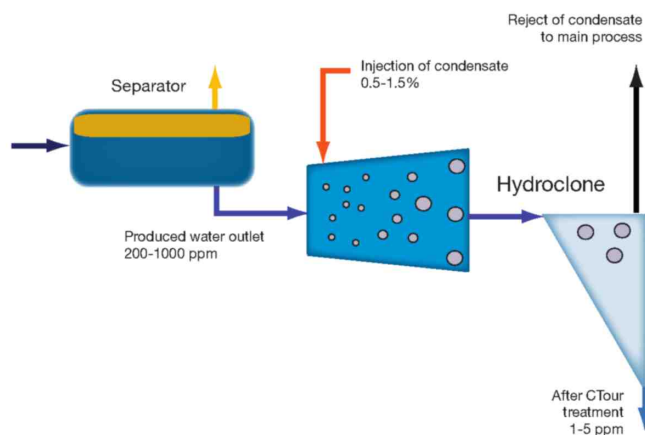

The TORR™ de-oiling technology, with its small footprint and ability to replace less efficient de-oiling equipment, exceeds today's discharge regulations in the treatment of produced water for offshore producers and operators.

The TORR™ technology is an efficient oil/water separator that can treat produced water at high inlet oil concentrations at a faster rate, thus potentially restoring the residence time in the primary separation vessel and therefore lowering the water content in the dehydrated crude.

The scalable technology addresses future increases in water cut.

TORR™ DE-OILING TECHNOLOGY



TORR™ INSTALLATION IN THE MIDDLE EAST



CONSIDERATIONS

- A properly designed chemical program will need to be in place to insure the proper functioning of the system and to possibly enhance performance beyond what the manufacturer can guarantee.
- When designing a produced water treatment system to handle substantial increase in water rates over the life of the field, remember that most control valves have an effective turndown ratio of 6:1 or less.
- Consider how the equipment performance will be affected over the life of the field and its changing process conditions.
- Assume there will always be more water than the reservoir engineers predicted; always build in some margin.



- If in doubt, pilot test. Non-conventional technologies are fine as long as their limitations and applicability are understood. Pilot-test any technologies unproven in a specific application.

REFERENCES

Available upon request.

FOR MORE INFORMATION

Contact your nearest ProSep office
www.prosep.com

About ProSep



ProSep is a technology-based process solutions provider for the upstream oil and gas industry.

The Company designs, develops, manufactures and commercializes technologies to separate oil, gas and water generated by oil and gas production.

ProSep's innovative offerings have been awarded three Spotlight on New Technology Awards from the annual Offshore Technology Conference in Houston in 2005 and onwards, comprising the proprietary technologies ProScav, C-Tour and ProSalt.

CANADA
+1 514 522 5550

KOREA
+82 2 521 3668

MALAYSIA
+603 2715 6680

MIDDLE EAST
+973 36 460142

NORWAY
+47 55 52 94 00

UNITED STATES
+1 281 504 2040